

FOR STANDARDS COMPLIANCE AND STANDARD FEATURES REFER TO PAGE D-3 AND RATED TO -50°F (-46°C).



**STANDARD MATERIAL LIST**

PART	MATERIAL	
1	Body	ASTM A352-LCC
2	Retainer	ASTM A352-LCC
3	Ball	ASTM A276-316
4	Stem	ASTM A276-316
5	Packing Gland	ASTM A108 Type 1215
6	Stem Seals	PTFE
7	Seats	RPTFE
8	Gland Screws	ASTM A193 B7
9	Gland Plate	302 & 304 SS
10	Stem Nut	316 SS
11	Lever	ASTM A366 Steel with Vinyl Grip
12	Stem Bearing	RPTFE
13	Stop	ASTM A108 Type 1215
14	Stop Screw	SAE J429 Grade 2
15	Lock Plate	ASTM A366 Steel
16	Body Seal	RPTFE
17	Lockwasher	302 or 304 SS
18	Grounding Spring	SS

**VARIATIONS AVAILABLE**

- 88L-730 Series (Ni-Cu Ball & Stem)

**OPTIONS AVAILABLE: (MORE INFORMATION IN SECTION J)**

- Minimum quantities apply
- To specify an option, replace the "01" standard suffix with the suffix of the option.
- To specify multiple options, replace the "01" suffix with the desired suffixes in the numerical order shown below. NOTE: Not all suffixes can be combined together.

(SUFFIX)	OPTION
-01	Standard Configuration
-04	2.25" Stem Extension (Carbon Steel, Zinc Plated)
-10	SS Lever and Nut
-14	Side Vented Ball (Uni-Directional). Not available with plated CS ball.
-15	Wheel Handle, Steel
-21	UHMWPE Seats
-24	Graphite packing, spiral wound graphite body seal, RPTFE bearing (API 607, 6th edition, ISO 10497:2010)
-26	Chlorine Service. Vented. Special Cleaning. Assembled dry. (for CS, Hastelloy and Ni-Cu valves. Ball must be Hastelloy or Ni-CU)
-35	PTFE Seats and Seals
-38	PEEK Seats and Graphite Packing
-49	No Lubrication. Assembled Dry.
-65	MPTFE Seats and Graphite Packing (Fire Safe)
-67	Cleaned For Industrial Gases
-69	Drilled and Tapped Purge Ports with Plugs
-70	4" Extended Bonnet
-73	316 SS Spiral Wound Gaskets w/PTFE Filler
-76	Live Loaded (Lever)
-77	Live Loaded (Gear, Actuator)
-80	Multi-Seal (Super TFE)
-82	Flat Face Flanges
-90	Double Packed 4" Extended Bonnet
-9P	Double Packed 4" Extended Bonnet with Monitoring Port
-CE	CE Marking. See Page D-3 "Product Approvals" for availability.
-EP	Garlock EVSP Stem Packing w/Spiral Wound Graphite Gasket (Fire Safe by Design)
-KF	PCTFE Stem Bearing
-TC	With Test Certificate
-TD	Tested to API Spec 6D
-UL	UL Listed

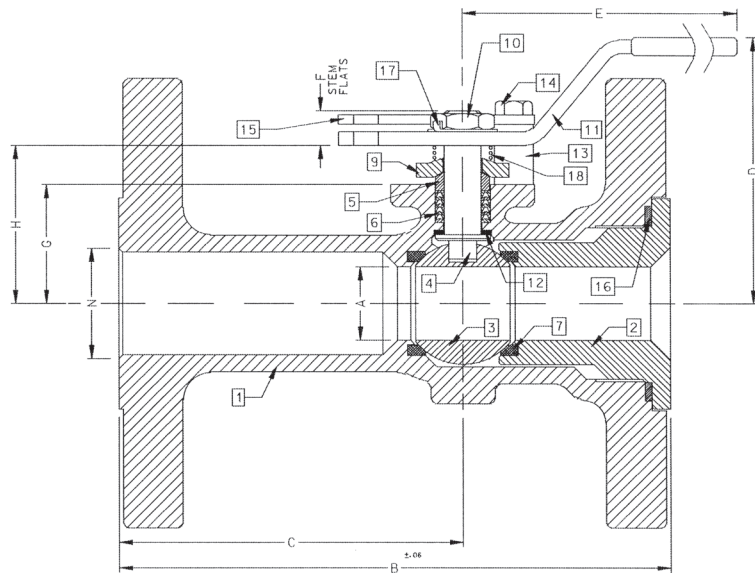

**ACTUATOR MOUNTING**

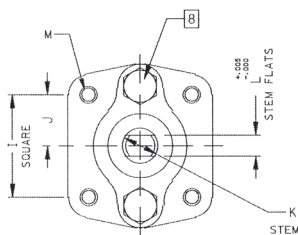

**DIMENSIONS**

PRODUCT NUMBER	SIZE	A	B	C	D	E	F	G	H	I	J	K	L	M	N	WT.
88L-747-01	1.5"	1.25	7.50	4.50	4.85	6.53	0.47	1.85	2.38	1.392	0.696	0.500	0.287	1/4-20	1.50	16
88L-748-01	2"	1.50	8.50	5.19	4.62	6.65	0.72	2.41	3.09	1.949	0.974	0.625	0.412	5/16-18	2.00	24

Pressure/Temperature Ratings - Page M-23, Graph No. 32



# 88L-740 SERIES

## LOW TEMP. CARBON STEEL ASME CLASS 300 FLANGED STD. PORT BALL VALVE - 2.5" THRU 3"

FOR STANDARDS COMPLIANCE AND STANDARD FEATURES REFER TO PAGE D-3 AND RATED TO -50°F (-46°C).



### STANDARD MATERIAL LIST

PART	MATERIAL	
1	Body	ASTM A352-LCC
2	Retainer	ASTM A352-LCC
3	Ball	ASTM A276-316 or A351-CF8M
4	Stem	ASTM A276-316
5	Packing Gland	ASTM A108 Type 1215
6	Stem Seals	PTFE
7	Seats	RPTFE
8	Gland Screws	ASTM A193 B7
9	Gland Plate	302 or 304 SS
10	Stem Nut	ASTM A194 Grade 8
11	Lever	ASTM A366 Steel with Vinyl Grip
12	Stem Bearing	RPTFE
13	Stop	ASTM A108 Type 1215
14	Stop Screw	SAE J429 Grade 2
15	Lock Plate	ASTM A366 Steel
16	Body Seal	RPTFE
17	Grounding Spring	SS
18	Body Joint Stud	ASTM A193 Grade B7
19	Body Joint Nut	ASTM A194 Grade 2H
20	Lockwasher	302 or 304 SS

### VARIATIONS AVAILABLE

- 88L-730 Series (Ni-Cu Ball & Stem)

### OPTIONS AVAILABLE: (MORE INFORMATION IN SECTION J)

- Minimum quantities apply
- To specify an option, replace the "01" standard suffix with the suffix of the option.
- To specify multiple options, replace the "01" suffix with the desired suffixes in the numerical order shown below. NOTE: Not all suffixes can be combined together.

(SUFFIX)	OPTION
-01	Standard Configuration
-04-	2.25" Stem Extension (Carbon Steel, Zinc Plated)
-10-	SS Lever and Nut
-14-	Side Vented Ball (Uni-Directional). Not available with plated CS ball.
-15-	Wheel Handle, Steel
-21-	UHMWPE Seats
-24-	Graphite packing, spiral wound graphite body seal, RPTFE bearing (API 607, 6th edition, ISO 10497:2010)
-26-	Chlorine Service. Vented. Special Cleaning. Assembled dry. (for CS, Hastelloy and Ni-Cu valves. Ball must be Hastelloy or Ni-Cu)
-35-	PTFE Seats and Seals
-38-	PEEK Seats and Graphite Packing
-49-	No Lubrication. Assembled Dry.
-59-	SS External Trim
-65-	MPTFE Seats and Graphite Packing (Fire Safe)
-67-	Cleaned For Industrial Gases
-69-	Drilled and Tapped Purge Port with Plug
-70-	4" Extended Bonnet
-73-	316 SS Spiral Wound Gaskets w/PTFE Filler
-76-	Live Loaded (Lever)
-77-	Live Loaded (Gear, Actuator)
-80-	Multi-Seal (Super TFE)
-82-	Flat Face Flanges
-90-	Double Packed 4" Extended Bonnet
-9P-	Double Packed 4" Extended Bonnet with Monitoring Port
-CE-	CE Marking. See Page D-3 "Product Approvals" for availability.
-EP-	Garlock EVSP Stem Packing w/Spiral Wound Graphite Gasket (Fire Safe by Design)
-KF-	PCTFE Stem Bearing
-MG-	Gear Operator with Standard Handwheel
-MH-	Gear Operator with Standard Handwheel & Locking Device
-MJ-	Gear Operator with Oversize Handwheel
-MK-	Gear Operator with Oversize Handwheel & Locking Device
-TC-	With Test Certificate
-TD-	Tested to API Spec 6D
-UL-	UL Listed

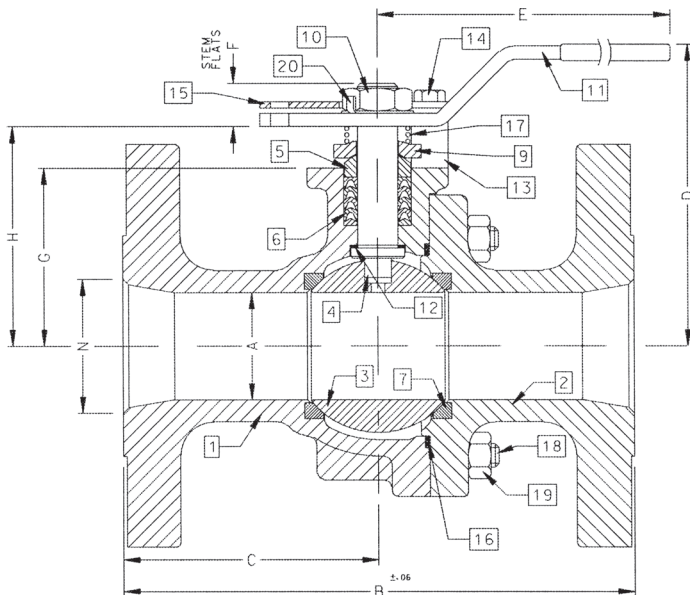

### ACTUATOR MOUNTING

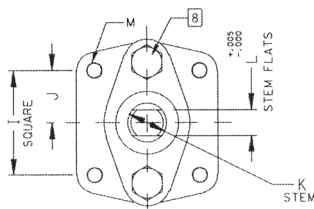

### DIMENSIONS

PRODUCT NUMBER	SIZE	A	B	C	D	E	F	G	H	I	J	K	L	M	N	WT.
88L-749-01	2.5"	2.00	9.50	4.75	5.61	8.41	0.80	3.31	4.08	1.949	0.974	0.750	0.477	5/16-18	2.50	39
88L-740-01	3"	2.50	11.12	5.56	6.24	8.41	0.80	3.94	4.71	1.949	0.974	0.750	0.477	5/16-18	3.00	55

Pressure/Temperature Ratings - Page M-23, Graph No. 32

FOR STANDARDS COMPLIANCE AND STANDARD FEATURES REFER TO PAGE D-3 AND RATED TO -50°F (-46°C).



**STANDARD MATERIAL LIST**

PART	MATERIAL	
1	Body	ASTM A352-LCC
2	Retainer	ASTM A352-LCC
3	Ball	ASTM A276-316 or A351-CF8M
4	Stem	ASTM A276-316
5	Packing Gland	ASTM A108 Type 1215
6	Stem Seals	PTFE
7	Seats	RPTFE
8	Gland Screws	ASTM A193 B7
9	Gland Plate	316 SS
10	Adapter Screw	316 SS
11	Handle Adapter	ASTM A366 Steel with Vinyl Grip
12	Stem Bearing	RPTFE
13	Stop	ASTM A108 Type 1215
14	Stop Screw	SAE J429 Grade 2
15	Lock Plate	ASTM A366 Steel
16	Body Seal	RPTFE
17	Grounding Spring	SS
18	Body Joint Stud	ASTM A193 Grade B7
19	Body Joint Nut	ASTM A194 Grade 2H
20	Adapter Screw	316 SS
21	Pipe Handle	Galvanized Steel (not shown)

**VARIATIONS AVAILABLE**

- 88L-730 Series (Ni-Cu Ball & Stem)

**OPTIONS AVAILABLE: (MORE INFORMATION IN SECTION J)**

- Minimum quantities apply
- To specify an option, replace the "01" standard suffix with the suffix of the option.
- To specify multiple options, replace the "01" suffix with the desired suffixes in the numerical order shown below. NOTE: Not all suffixes can be combined together.

(SUFFIX)	OPTION
-01	Standard Configuration
-14-	Side Vented Ball (Uni-Directional). Not available with plated CS ball.
-21-	UHMWPE Seats
-24-	Graphite packing, spiral wound graphite body seal, RPTFE bearing (API 607, 6th edition, ISO 10497:2010)
-26-	Chlorine Service. Vented. Special Cleaning. Assembled dry. (for CS, Hastelloy and Ni-Cu valves. Ball must be Hastelloy or Ni-CU)
-35-	PTFE Seats and Seals
-49-	No Lubrication. Assembled Dry.
-59-	SS External Trim
-65-	MPTFE Seats and Graphite Packing (Fire Safe)
-67-	Cleaned For Industrial Gases
-69-	Drilled and Tapped Purge Ports with Plugs
-70-	4" Extended Bonnet
-73-	316 SS Spiral Wound Gaskets w/PTFE Filler
-76-	Live Loaded (Lever)
-77-	Live Loaded (Gear, Actuator)
-80-	Multi-Seal (Super TFE)
-82-	Flat Face Flanges
-90-	Double Packed 4" Extended Bonnet
-9P-	Double Packed 4" Extended Bonnet with Monitoring Port
-CE-	CE Marking. See Page D-3 "Product Approvals" for availability.
-EP-	Garlock EVSP Stem Packing w/Spiral Wound Graphite Gasket (Fire Safe by Design)
-KF-	PCTFE Stem Bearing
-MG-	Gear Operator with Standard Handwheel
-MH-	Gear Operator with Standard Handwheel & Locking Device
-MJ-	Gear Operator with Oversize Handwheel
-MK-	Gear Operator with Oversize Handwheel & Locking Device
-TC-	With Test Certificate
-TD-	Tested to API Spec 6D
-UL-	UL Listed

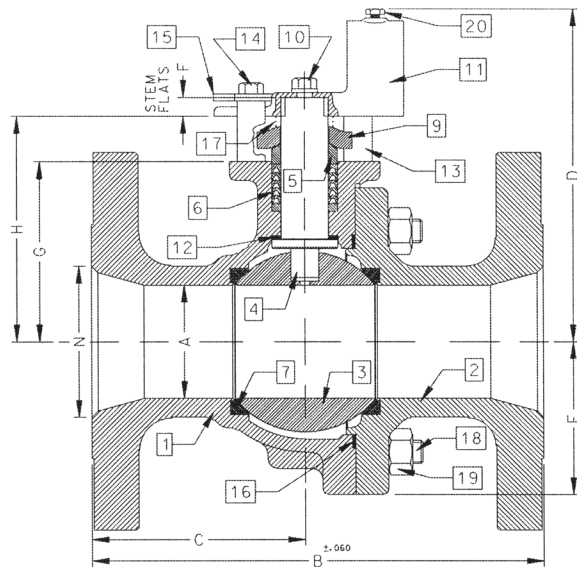

**ACTUATOR MOUNTING**

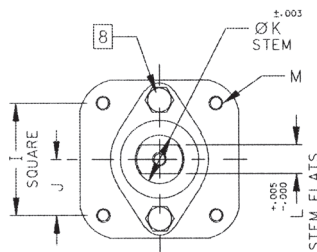

**DIMENSIONS**

PRODUCT NUMBER	SIZE	A	B	C	D	E	F	G	H	I	J	K	L	M	N	WT.
88L-74A-01	4"	3.00	12.00	5.68	8.80	4.06	0.50	4.75	5.95	2.840	1.420	1.250	0.725	3/8-16	4.00	95
88L-74C-01	6"	4.00	15.88	7.38	9.99	5.25	0.50	5.94	7.13	2.840	1.420	1.250	0.725	3/8-16	6.00	187
88L-74E-01	8"	6.00	19.75	9.00	13.73	7.30	1.00	7.75	9.48	4.596	2.298	2.000	1.375	3/4-10	8.00	400

Pressure/Temperature Ratings - Page M-23, Graph No. 32



# 88L-740 SERIES

## LOW TEMP. CARBON STEEL ASME CLASS 300 FLANGED STD. PORT BALL VALVE - 10"

FOR STANDARDS COMPLIANCE AND STANDARD FEATURES REFER TO PAGE D-3 AND RATED TO -50°F (-46°C).



### STANDARD MATERIAL LIST

PART	MATERIAL
1	Body
2	Retainer
3	Ball
4	Stem
5	Packing Gland
6	Stem Seals
7	Seats
8	Gland Screws
9	Gland Plate
10	Stem Bearing
11	Body Seal
12	Body Joint Stud
13	Body Joint Nut

### VARIATIONS AVAILABLE

- 88L-730 Series (Ni-Cu Ball & Stem)

### OPTIONS AVAILABLE: (MORE INFORMATION IN SECTION J)

- Minimum quantities apply
- To specify an option, replace the "01" standard suffix with the suffix of the option.
- To specify multiple options, replace the "01" suffix with the desired suffixes in the numerical order shown below. NOTE: Not all suffixes can be combined together.

(SUFFIX)	OPTION
-01	Standard Configuration
-14-	Side Vented Ball (Uni-Directional). Not available with plated CS ball.
-21-	UHMWPE Seats
-24-	Graphite packing, spiral wound graphite body seal, RPTFE bearing (API 607, 6th edition, ISO 10497:2010)
-26-	Chlorine Service. Vented. Special Cleaning. Assembled dry. (for CS, Hastelloy and Ni-Cu valves. Ball must be Hastelloy or Ni-CU)
-35-	PTFE Seats and Seals
-49-	No Lubrication. Assembled Dry.
-57-	Oxygen Cleaned
-65-	MPTFE Seats and Graphite Packing (Fire Safe)
-67-	Cleaned For Industrial Gases
-69-	Drilled and Tapped Purge Port with Plugs
-70-	4" Extended Bonnet
-77-	Live Loaded (Gear, Actuator)
-80-	Multi-Seal (Super TFE)
-82-	Flat Face Flanges
-90-	Double Packed 4" Extended Bonnet
-9P-	Double Packed 4" Extended Bonnet with Monitoring Port
-CE-	CE Marking. See Page D-3 "Product Approvals" for availability.
-EP-	Garlock EVSP Stem Packing w/Spiral Wound Graphite Gasket (Fire Safe by Design)
-KF-	PCTFE Stem Bearing
-MG-	Gear Operator with Standard Handwheel
-MH-	Gear Operator with Standard Handwheel & Locking Device
-MJ-	Gear Operator with Oversize Handwheel
-MK-	Gear Operator with Oversize Handwheel & Locking Device
-TC-	With Test Certificate
-TD-	Tested to API Spec 6D
-UL-	UL Listed

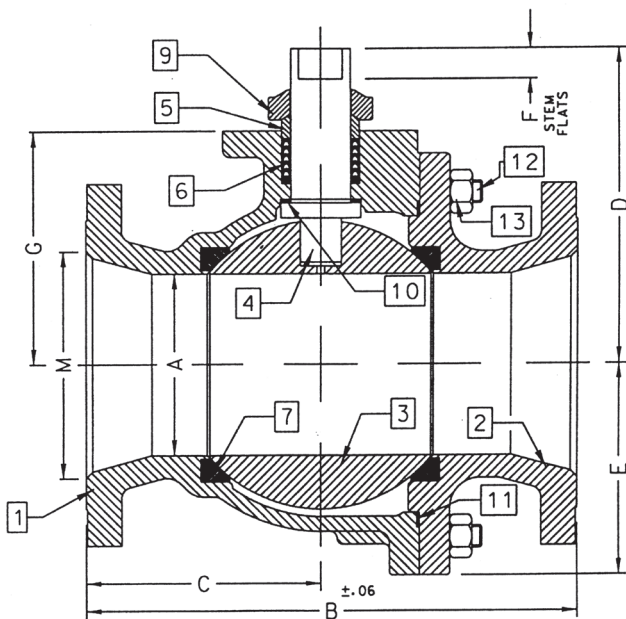

### ACTUATOR MOUNTING

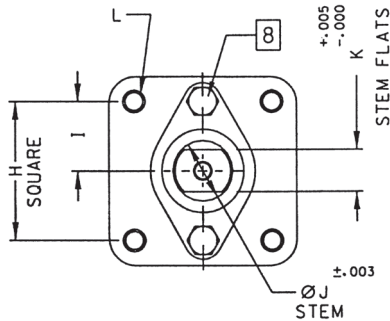

Pressure/Temperature Ratings - Page M-23, Graph No. 32

### DIMENSIONS

PRODUCT NUMBER	SIZE	A	B	C	D	E	F	G	H	I	J	K	L	M
88L-74G-01	10"	8.00	22.38	10.69	12.83	9.56	1.00	10.22	4.596	2.298	2.000	1.375	3/4-10	10.00

REV. 04MAY17

The listed  $C_v$  “factors” are derived from actual flow testing, in the Apollo® Ball Valve Division, Conbraco Industries, Inc., Pageland, South Carolina. These tests were completed using standard “off the shelf” valves with no special preparation and utilizing standard schedule 40 pipe. It should be understood that these factors are for the valve only and also include the connection configuration. The flow testing is done utilizing water as a fluid media and is a direct statement of the gallons of water flowed per minute with a 1 psig pressure differential across the valve/connection unit. Line pressure is not a factor. Because the  $C_v$  is a factor, the formula can be used to estimate flow of most media for valve sizing.

### FLOW OF LIQUID

$$Q = C_v \sqrt{\frac{\Delta P}{SpGr}}$$

$$\text{or } \Delta P = \frac{(Q)^2 (SpGr)}{(C_v)^2}$$

#### WHERE:

- Q = Flow in US gpm
- ΔP = Pressure drop (psig)
- SpGr = Specific gravity at flowing temperature
- $C_v$  = Valve constant

### FLOW OF GAS

$$Q = 1360 C_v \sqrt{\frac{(\Delta P) (P_2)}{(SpGr) (T)}}$$

$$\text{or } \Delta P = \frac{5.4 \times 10^{-7} (SpGr) (T) (Q)^2}{(C_v)^2 (P_2)}$$

#### WHERE:

- Q = Flow in SCFH
- ΔP = Pressure drop (psig)
- SpGr = Specific gravity (based on air = 1.0)
- P2 = Outlet pressure-psia (psig + 14.7)
- T = (temp. °F + 460)
- $C_v$  = Valve constant

**CAUTION:** The gas equation shown, is valid at very low pressure drop ratios. The gas equation is NOT valid when the ratio of pressure drop (ΔP) to inlet pressure (P1) exceeds 0.02.

**NOTE:** Only use the gas equation shown if (P1-P2)/P1 is less than 0.02.

### Cv FACTORS FOR APOLLO VALVES (continued on M-4)

VALVE	SIZE (IN.)														
	1/4	3/8	1/2	3/4	1	1.25	1.5	2	2.5	3	4	6	8	10	12
70B-140 Series	8.4	7.2	15	30	43	48	84	108	190	370	670	--	--	--	--
70-100/200 Series	8.4	7.2	15	30	43	48	84	108	190	370	670	--	--	--	--
70-300/400 Series	--	--	15	30	43	48	84	108	--	--	--	--	--	--	--
70-600 Series	2.3	4.5	5.4	12	14	21	34	47	--	--	--	--	--	--	--
70-800 Series	8.4	7.2	15	30	43	48	84	--	--	--	--	--	--	--	--
71-AR Series	--	--	--	30	43	48	84	108	190	370	--	--	--	--	--
71-100/200 Series	--	--	--	30	43	48	84	108	190	370	--	--	--	--	--
72-100/900 Series	--	--	26	48	65	125	170	216	--	--	--	--	--	--	--
72-1xx-A/72-9xx-A Series	--	--	26	48	65	125	170	245	--	--	--	--	--	--	--
73A-100 Series	8.4	7.2	15	30	43	48	84	108	--	--	--	--	--	--	--
73-300/400 Series	--	--	26	48	65	125	170	216	--	--	--	--	--	--	--
74-100 Series	8.4	7.2	15	30	43	48	84	108	190	370	670	--	--	--	--
75-100 Series	8.4	7.2	15	30	43	48	84	108	190	370	670	--	--	--	--
76-AR Series	8.4	7.2	15	30	43	48	84	108	190	370	670	--	--	--	--
76F-100 Series	8.1	15	15	51	68	125	177	389	--	--	--	--	--	--	--
76FJ-100 Series	8.1	15	15	51	68	125	177	389	--	--	--	--	--	--	--
76FK-100 Series	8.1	15	15	51	68	125	177	389	--	--	--	--	--	--	--
76-100 Series	8.4	7.2	15	30	43	48	84	108	190	370	--	--	--	--	--
76-300/400 Series	--	--	26	48	65	125	170	216	--	--	--	--	--	--	--
76-600 Series	2.3	4.5	5.4	12	14	21	34	47	--	--	--	--	--	--	--
76J-100 Series	8.4	7.2	15	30	43	48	84	108	190	370	--	--	--	--	--
76J-AR Series	8.4	7.2	15	30	43	48	84	108	190	370	670	--	--	--	--
76K-100 Series	8.4	7.2	15	30	43	48	84	108	190	370	--	--	--	--	--
76K-AR Series	8.4	7.2	15	30	43	48	84	108	190	370	670	--	--	--	--
7K-100 Series	--	--	15	51	68	125	177	389	503	--	--	--	--	--	--
77-AR Series	8.1	15	15	51	68	--	177	389	--	--	--	--	--	--	--

# FLOW DATA FOR APOLLO® BALL VALVES

## Cv FACTORS FOR APOLLO VALVES (continued from M-3)

VALVE	SIZE (IN.)														
	1/4	3/8	1/2	3/4	1	1.25	1.5	2	2.5	3	4	6	8	10	12
77C-100/200 Series	4.5	7.2	16	36	68	125	177	389	503	--	--	--	--	--	--
77D-140 Series	4.5	7.2	16	36	68	125	177	389	--	--	--	--	--	--	--
77D-640 Series	--	--	--	11	24	35	--	--	--	--	--	--	--	--	--
77G-UL Series	4.5	7.2	16	36	68	125	177	389	503	--	--	--	--	--	--
77W Series	--	--	16	36	68	125	177	389	--	--	--	--	--	--	--
77-100/200 Series	8.1	15	15	51	68	125	177	389	503	--	--	--	--	--	--
79 Series	8.5	8.5	9.8	32	44	66	148	218	440	390	--	--	--	--	--
80 Series	8.4	7.2	15	30	43	48	84	108	190	370	--	--	--	--	--
82-100/200 Series	8.1	14	26	51	68	120	170	376	510	996	1893	--	--	--	--
83A/83B Series	8.1	14	26	51	68	120	170	376	--	--	--	--	--	--	--
83R-100/200 Series	--	--	--	--	--	--	170	376	--	996	1893	--	--	--	--
86A/86B Series	8.1	14	26	51	68	120	170	376	--	--	--	--	--	--	--
86R-100/200 Series	--	--	--	--	--	--	170	376	--	996	1893	--	--	--	--
87A-100 Series	--	--	--	--	--	--	86	104	234	375	673	1099	1902	3890	--
87A-200 Series	--	--	15	19	75	--	195	410	545	1021	2016	4837	9250	15170	22390
87A-700 Series	--	--	--	--	--	--	86	104	234	375	673	1099	1902	3890	--
87A-900 Series	--	--	15	19	75	--	195	410	545	1021	2016	4837	9250	15170	22390
87A-F00 Series	--	--	--	--	75	--	195	410	545	1021	2016	4837	--	--	--
87B-100 Series	--	--	--	--	--	--	--	--	375	673	1099	1902	3890	--	--
87J-100 Series	--	--	--	--	--	--	86	104	234	375	673	1099	1902	3890	--
87J-200 Series	--	--	15	19	75	--	195	410	545	1021	2016	4837	9250	15170	22390
87J-700 Series	--	--	--	--	--	--	86	104	234	375	673	1099	1902	3890	--
87J-900 Series	--	--	15	19	75	--	195	410	545	1021	2016	4837	9250	15170	22390
87K-100 Series	--	--	--	--	--	--	86	104	234	375	673	1099	1902	3890	--
87K-200 Series	--	--	15	19	75	--	195	410	545	1021	2016	4837	9250	15170	22390
87K-700 Series	--	--	--	--	--	--	86	104	234	375	673	1099	1902	3890	--
87K-900 Series	--	--	15	19	75	--	195	410	545	1021	2016	4837	9250	15170	22390
88A-100 Series	--	--	--	--	--	--	86	104	234	375	673	1099	1902	3890	--
88A-200 Series	--	--	15	19	75	--	195	410	545	1021	2016	4837	9250	15170	22390
88A-700 Series	--	--	--	--	--	--	86	104	234	375	673	1099	1902	3890	--
88A-900 Series	--	--	15	19	75	--	195	410	545	1021	2016	4837	9250	15170	22390
88A-F00 Series	--	--	--	--	75	--	195	410	545	1021	2016	4837	--	--	--
88B-100 Series	--	--	--	--	--	--	--	--	375	673	1099	1902	3890	--	--
89-100 Series	8.4	7.2	15	30	43	48	84	108	190	370	--	--	--	--	--
9A-100 Series	8.3	6.7	5.7	10	16	25	40	62	--	--	--	--	--	--	--
90-100 Series	8.3	6.7	5.7	10	16	25	40	62	--	--	--	--	--	--	--
92-100 Series	8.3	6.7	5.7	10	16	25	40	62	--	--	--	--	--	--	--
93-100 Series	8.3	6.7	5.7	10	16	25	40	62	--	--	--	--	--	--	--
94A-100/200 Series	6	7	19	34	50	104	268	309	629	1018	1622	--	--	--	--
96-100 Series	8.3	6.7	5.7	10	16	25	40	62	--	--	--	--	--	--	--
399-100 Series	8.4	7.2	15	30	43	48	84	108	190	370	--	--	--	--	--
489-100 Series	8.4	7.2	15	30	43	48	84	108	190	370	--	--	--	--	--

Steel castings for low temperature service.

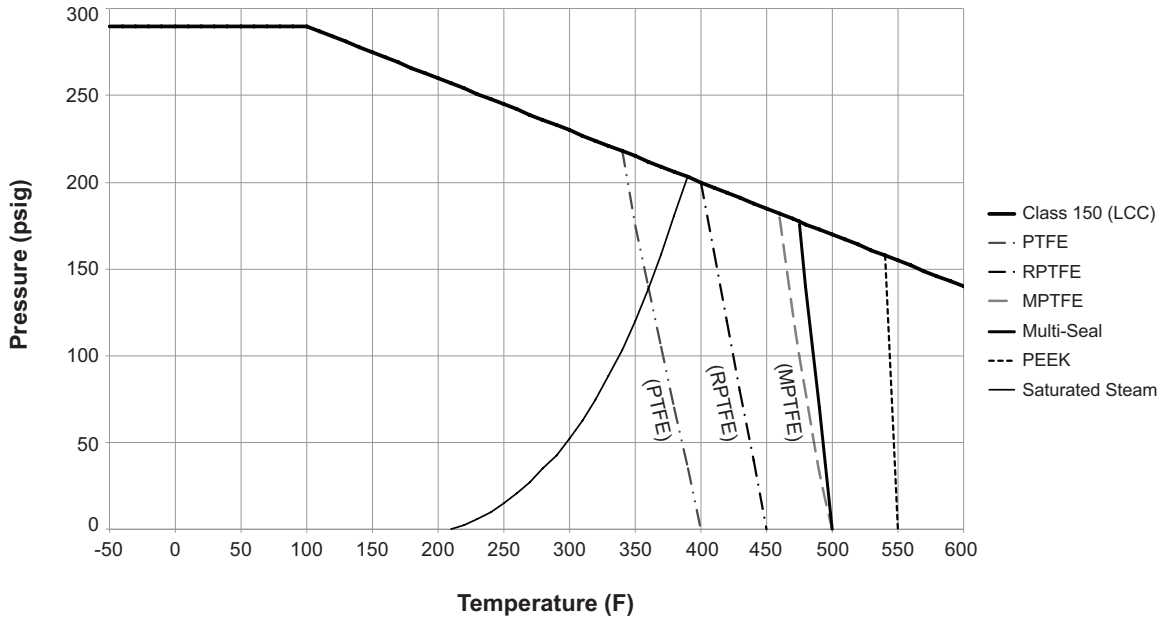

Steel castings for low temperature service.

